

Slat Wall System

SCHEDA TECNICA

PROPRIETÀ

SLAT WALL SYSTEM		SUPPORTO	MODELLO	RIVESTIMENTO	FINITURA
QUOTE SENZA INDICAZIONE DI TOLLERANZA +/- 0,2	3050X50X30	MDF CARB.	SQUARE	EU. OAK	RAW BRUSHED
			SQUARE	EU. OAK	NATURAL CLEAR 10 GLOSS
		COD.SAGOMA PB100	SQUARE	U.S.A. WALNUT	RAW SANDED
			SQUARE	U.S.A. WALNUT	NATURAL CLEAR 10 GLOSS
			SQUARE	PAPER	FINISH FOIL
MINI SLAT WALL SYSTEM					
QUOTE SENZA INDICAZIONE DI TOLLERANZA +/- 0,2	3050X100X18	MDF CARB.	MINI SLAT	ROVERE EUR	GREZZO LEVIGATO
		COD.SAGOMA PB115	MINI SLAT	NOCE CANALETTO	GREZZO LEVIGATO

FRONTAL VIEW

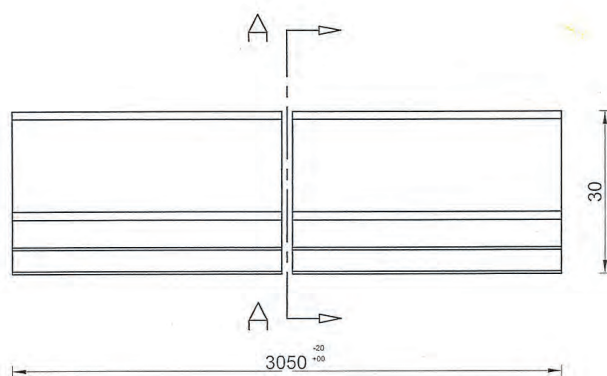

SECTION A-A

